



Laboratory Equipment Manufacturer
www.mrclab.com



Steam Sterilizer

Operation Manual

STE-HT SERIES



PLEASE READ THIS MANUAL CAREFULLY BEFORE OPERATION

3, Hagavish st. Israel 58817 Tel: 972 3 5595252, Fax: 972 3 5594529 mrc@mrclab.com

MRC.12.20

Table of Contents

Introduction	4
1 Equipment installation.....	7
1.1 Unpacking.....	7
1.2 Equipment installation.....	7
1.2.1 Installation space requirements.....	7
1.2.2 Horizontal debugging.....	9
1.2.3 Power and water supply requirements.....	9
1.3 Accessories checking.....	11
2 Equipment debugging.....	11
2.1 Power supply.....	11
2.2 Operation of keys and display.....	11
2.3 Parameter setting.....	14
2.3.1 Atmosphere parameter setting.....	14
2.3.2 Preheating mode setting.....	15
2.4 Equipment connector instruction.....	15
2.4.1 Water tank outlet a.....	15
2.4.2 Steam generator water outlet d.....	16
2.5 Water injection operation.....	17
2.6 Operation of opening/closing door.....	18
2.7 Operation of sterilization program.....	21
2.8 Operation of vacuum test program.....	22
2.9 End of installation and debugging.....	22
3 Display screen instructions.....	22
3.1 Initial page.....	22
3.2 Program selection & start page.....	23
3.2.1 Program selection page.....	23
3.2.2 Program start page.....	23
3.3 Setting page.....	24
3.3.1 System parameter setting.....	24
3.3.2 Pressure point.....	25
3.3.3 Preheat.....	25
3.3.4 Print mode.....	25
3.3.5 Time/Date.....	26
3.3.6 Language.....	26
3.3.7 USB connection status.....	26
3.4 Maintenance.....	27
3.4.1 Equipinfo.....	27
3.4.2 Deviation.....	28
3.4.3 Manual.....	28
3.4.4 Password set.....	29
3.4.5 Water test.....	29
3.4.6 Resume PARA.....	29

3.4.7	Program parameters setting.....	29
3.5	Program Pages.....	30
3.5.1	Main process page.....	30
3.5.2	Parameter view.....	30
3.6	Output information.....	31
3.7	Process data.....	32
3.8	Alarm information.....	32
3.9	Program stop.....	34
3.10	Other pages.....	34
3.10.1	Input/output view.....	34
3.10.2	Vacuum test.....	35
3.10.3	Alarm prompting.....	35
4	Operation instructions.....	35
4.1	Instructions on keys.....	35
4.1.1	Return key.....	36
4.1.2	Ok key.....	36
4.1.3	Up key.....	36
4.1.4	Down key.....	36
4.1.5	Open key.....	36
4.1.6	Cursor.....	36
4.2	Program parameters setting.....	37
5	Operation steps of sterilization.....	39
5.1	Preparation.....	39
5.2	Operation of sterilization.....	40
5.3	Cleaning and maintenance.....	41
Appendix 1	Operation specification.....	43

Introduction

This manual is suitable for the installation, operation and maintenance of STE-HT series normal pressure steam sterilizer.

Publication date: 16/03/2013

Welcome to use MRC STE-HT series Steam Sterilizer. To bring the maximum performance into full play and ensure that the product operate safely, please read the manual carefully first and strictly comply with the requirements of installation, operation and maintenance mentioned in this manual.

The following symbols in the manual are used to get highly attention and caution:



Caution: Highly attention should be paid.



Warning: The cases possibly cause equipment damage.



Danger: The cases possibly endanger personal safety.

Please read each chapter carefully and fully understand it before any operation, maintenance on the product especially the contents with the above symbols.

Please properly keep this manual away from loss and damage.

The operator has responsibility to renovate the manual and complete the lost, damaged or unsuitable contents.



Caution

Anyone in any situation cannot tear off any page from the manual. During the usage of the product, please do not hesitate to contact us if there is any inconsistent explanation or unmentioned cases. We will timely solve the problems and update or renew the manual for free.

This manual booklet should be stored in dry and ventilated place without high temperature.

This manual is applicable for the following products:

Model	Chamber Dim (mm)	Overall Dim (mm)	Power Supply	Rated Power
STE-HT-60	385×595 (Φ×L)	1002×730×560	220v 50/60Hz	7000W
STE-HT-80	385×717 (Φ×L)	1002×730×560	220v 50/60Hz	7000W

Design pressure: -0.1/0.3mpa
Design temperature: 144℃
Working pressure: 0.25mpa
Vacuum limit: -0.08mpa
Temperature range: 105~136℃
Temperature display accuracy: 0.1℃
Pressure display accuracy: 1kpa

Instructions



Caution

Please keep this manual completely during the equipment service life and ensure that all the updated information is included in this manual. In the case of that the equipment must be transferred to a new site, please make sure that the manual should be transferred as a part of the equipment. The following symbols in the manual are used to get highly attention and caution:



Caution: Highly attention should be paid.



Warning: The cases possibly cause equipment damage.



Danger: The cases possibly endanger personal safety.

Please read each chapter carefully and fully understand it before any operation, maintenance on the product especially the contents with the above symbols.

Please properly keep this manual away from loss and damage.

The operator has responsibility to renovate the manual and complete the lost, damaged or unsuitable contents.



Warning:

The product is not applicable for unsealed bottled liquid. Please contact us to order special liquid sterilizer.



Danger:

The bottle explosion that could endanger the personal and product safety may happen, if bottled liquid with tight seal is sterilized by this product.



Caution:

Since the chloridion is the important factor of corroding stainless steel, if the items that contain chloridion are sterilized by this product please wash the chamber everyday by clean water to increase the product service life.

Otherwise, the chloridion may corrode the chamber.



Warning:

The improper operation (i.e. sterilize the items that contain chloridion without washing the chamber everyday) that decreases the product service life is not included into our warranty.



Caution:

In order to adopt proper measures when you see the  sign in any place please consult the manual or other relevant document to clarify the potential danger.



Caution:



Indicates high temperature, please protect yourself from scald when you see this sign.

1 Equipment installation

1.1 Unpacking

◇Unpacking

Open the top lid of the packing case first then remove the four flaps successively. Finally, remove the plastic film from the equipment.

◇Equipment appearance checking

- After unpacking the equipment, please check the consistency of equipment model and name between nameplate and the order form. (The nameplate is on the back outer cover of the equipment.)
- Please make a record and contact us or the transport company if there is any damage.

1.2 Equipment installation

During the installation, qualified staff should record the equipment name and model with the guidance of professionals in order to contact us for technology consulting.

1.2.1 Installation space requirements

Installation environment checking: please make sure that the space size, table-board, temperature and humidity have met the following requirements:

- For equipment operation and maintenance reasons, the height of space for equipment installation should be no less than 1.5m;
- The gap between wall and left/right side of the equipment should be no less than 0.5m;
- The depth of equipment loading/unloading direction should be no less than 1.5 times of equipment length to easily carry the items that to be sterilized.

The figures marked in the following drawing indicate the minimum size of the installation space:

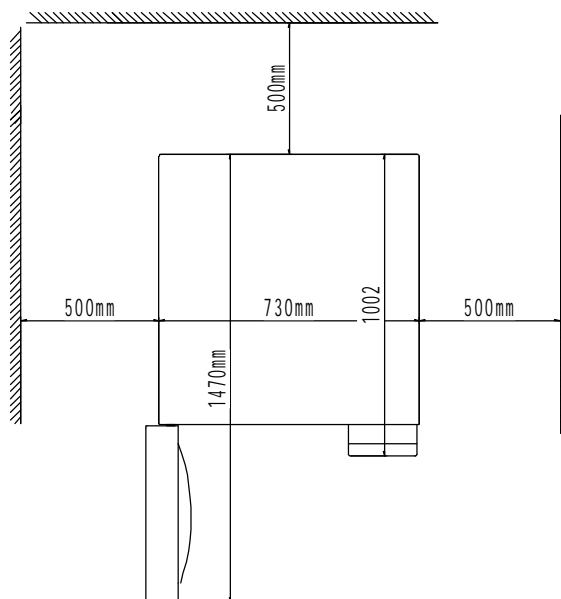

◇Table-board requirements

Equipment net weight: 180kg

Equipment under-chassis quantity: 4

Under-chassis bearable load: 28N/cm²

The surface of the table-board should be firm and smooth and the load-bearing should meet relevant requirements.

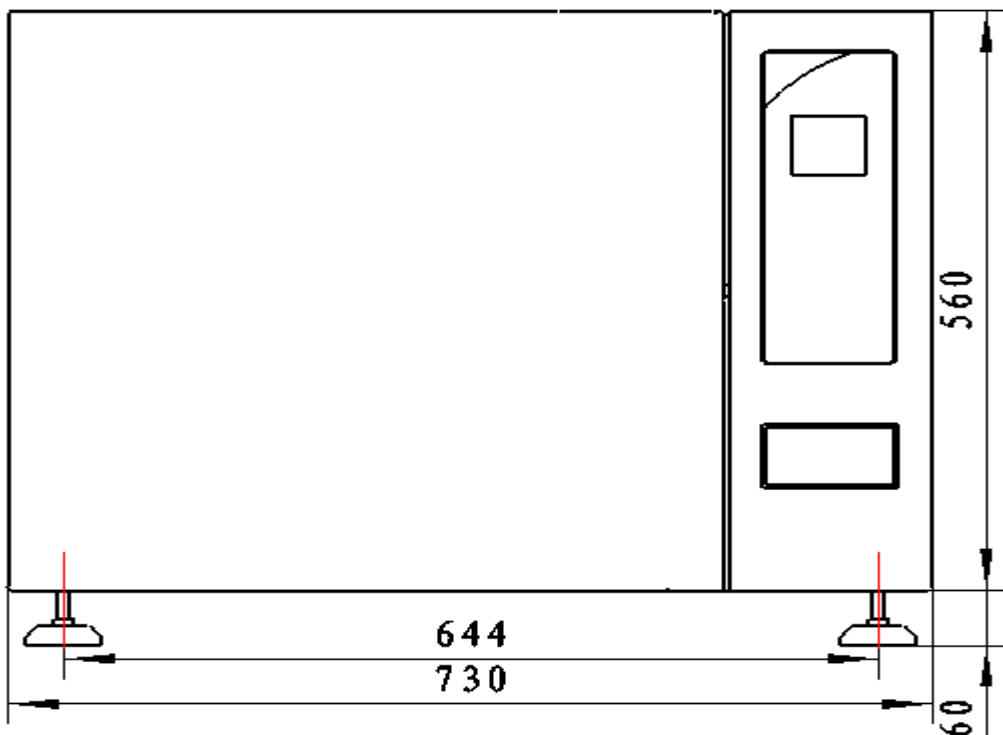
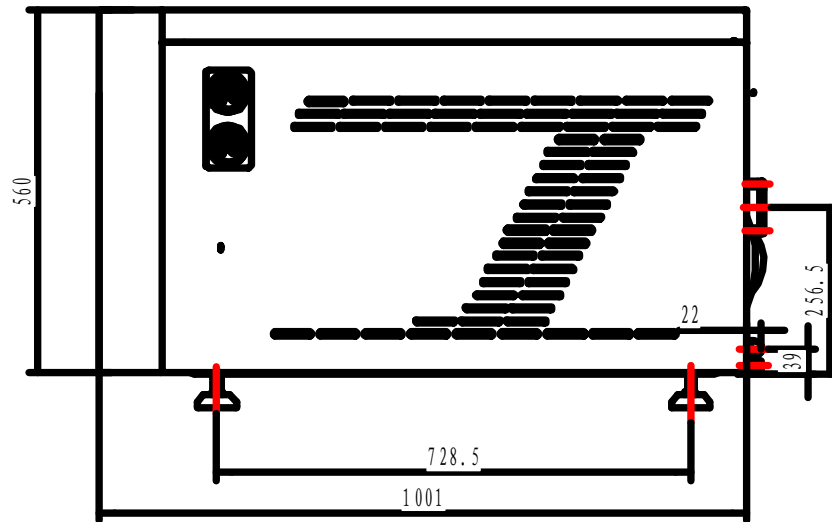

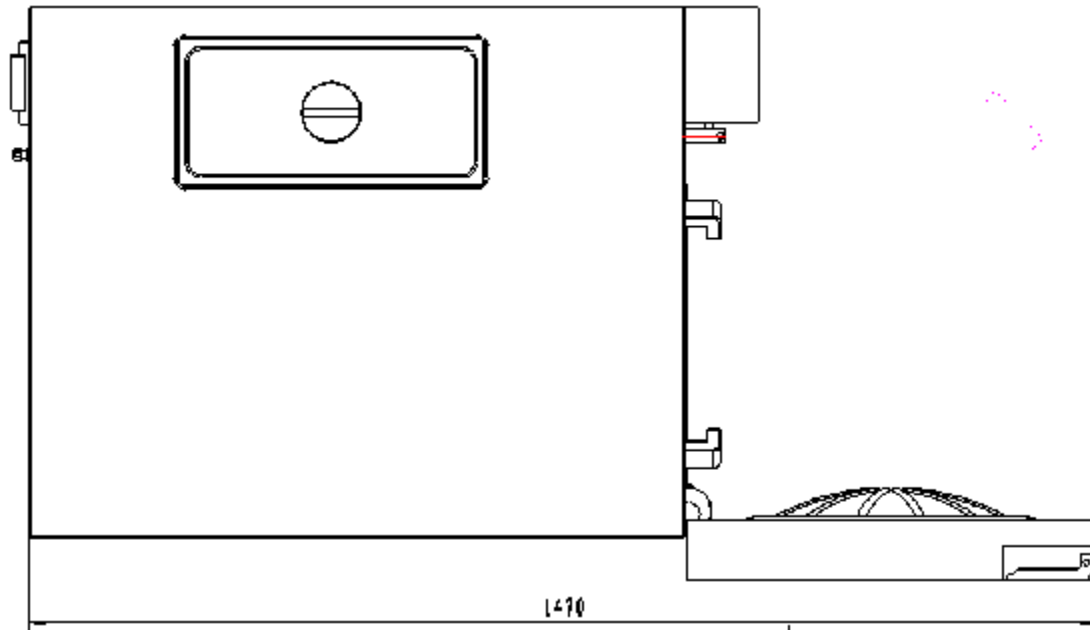

◇Ventilation and heat dissipation

In order to ensure the equipment operates normally in a good working environment, we suggest that it is necessary to install a suitable ventilation system to control the temperature and humidity around the equipment. In that case, the working environment temperature will not exceed 50°C, while the humidity will not exceed 85% when the temperature is 20°C.

1.2.2 Horizontal debugging

Once the equipment is placed on the table-board please adjust the equipment height according to the following drawing to prevent too much water accumulated in the equipment. (The air and water outlet are in the back end of equipment.)

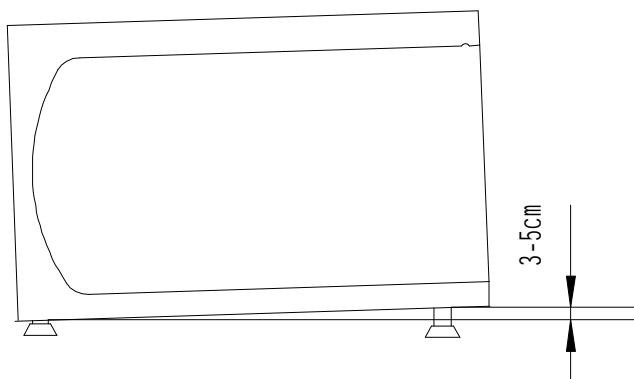

1.2.3 Power and water supply requirements

◇After placement please check if the power supply meets these requirements:

220V AC 50Hz/60Hz single phase; fluctuation range: $\pm 10\%$

Power supply cable diameter: $\geq 6\text{mm}^2$

Please connect the cable to power circuit breaker or switch according to the following method:

The cable includes three lines which are fire line (brown), zero line (blue) and earth line (kelly). The load capacity of user power and cable should be greater than the

required capacity. It is required to install a power switch box on the right side of the equipment or back right wall. A three-phase chopper switch (or a breaker) and single-phase chopper switch (or a breaker) installed must be installed in the switch box. For specially made equipment wiring, please refer to the actual requirement written on the sales agreement.

◇Water supply

There is no need to connect the equipment with external water supply. Please inject water manually into the equipment build-in water tank.

Only pure water can be used and the water quality must meet the following requirements:

- a) Electrical conductivity: $\leq 15\mu\text{S}/\text{cm}$
- b) Bleach concentration: $\leq 2\text{mg}/\text{l}$
- c) PH value: 5-7
- d) Hardness: $\leq 0.02\text{mmol}/\text{l}$

The water amount should at least exceed the low level mark that is 16L approximately.



The water injected should be in the between of 'high level' and 'low level' mark.



Caution:

After water injection if the system indicates that the water quality is poor, please change another tank of water in good quality.



Warning: The water used for equipment must be pure water.



Caution:

To prevent any safety problem caused by components damage, please install electric leakage protection device.

For personal and equipment safety, an earth line must be wired. Also, the earth line of equipment outer cover and control cable must be reliably grounded.



Danger: The equipment must be reliably grounded!

1.3 Accessories checking

- ◇ Please check the intactness of the equipment components according to the packing list. If any damage or loss is found please make a record and contact us in time.
- ◇ Check the fastness of all connectors and fasteners. Please refasten them if there is any looseness.
- ◇ Check and record all attached accessories.



Caution:

Please switch on the power before opening the door! For door operation please refer to the relevant information in this manual.

2 Equipment debugging

2.1 Power supply

Firstly, make sure the voltage of the power supply is AC220V 50/60Hz; the fluctuation range is no more than $\pm 10\%$. Check the power circuit breaker (on the back of equipment) if it is closed.

Secondly, switch the power key to '1' position to turn on the power. Check whether the preheating mode is on. The water injection pump will start working if the preheating mode is on. Do not keep the water injection pump works for too long with no water in the tank. It is better to turn off the preheating mode before injecting the water tank.

2.2 Operation of keys and display

2.2.1

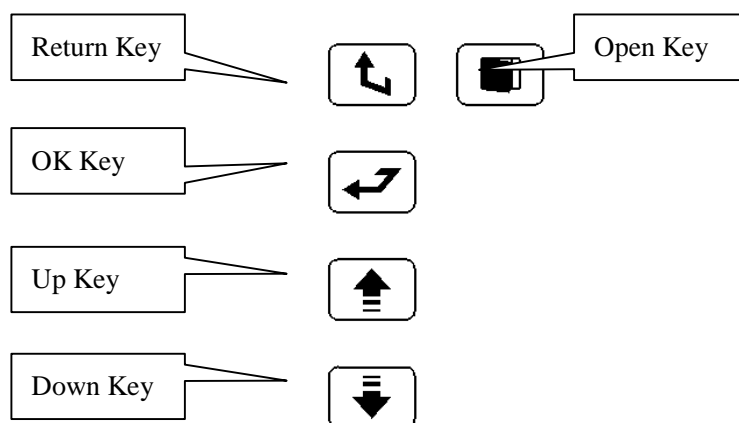

1) Return Key

Press this key so as to return to the previous page.

2) OK Key

1 Press this key so as to select the icon.

l When setting the parameters, this key can be used to move the cursor.

3) Up Key

l Press this key so as to move the cursor upwards or leftwards.

l When setting the parameters, this key can be used to increase the value.

l This key can be used to change the page.

4) Down Key

l Press this key, so as to move the cursor downwards or rightwards

l When setting the parameters, this key can be used to decrease the value.

l This key can be used to change the page.

5) Open Key

Press 'open' key or simply twist the door handle to open the equipment door.











However, the door will close automatically if you do not completely open the door after pressing 'open' key.

2.2.2 The screen can display normally without flashing, messy code and display

failure. When the cursor is moved to an icon the color will be like this:  



Table 1

	Icon	Function
1		Select this icon and press ok to enter into program types page;
2		Select this icon and press ok to enter into parameter setting page;
3		Select this icon and press ok to enter into system maintenance parameter setting page;
4		Select this icon and press ok to enter into alarm information page;
5		Select this icon and press ok to enter into program running page;
6		Select this icon and press ok to enter into parameter viewing page;
7		Select this icon and press ok to view parameters during the process of program;
8		Select this icon and press ok to enter into output point information page;
9		Select this icon and press ok to enter into process data viewing page;
10		Select this icon and press ok to enter into program exit prompt page;

2.3 Parameter setting

2.3.1 Atmosphere parameter setting

(See next page)

Parameter setting process:

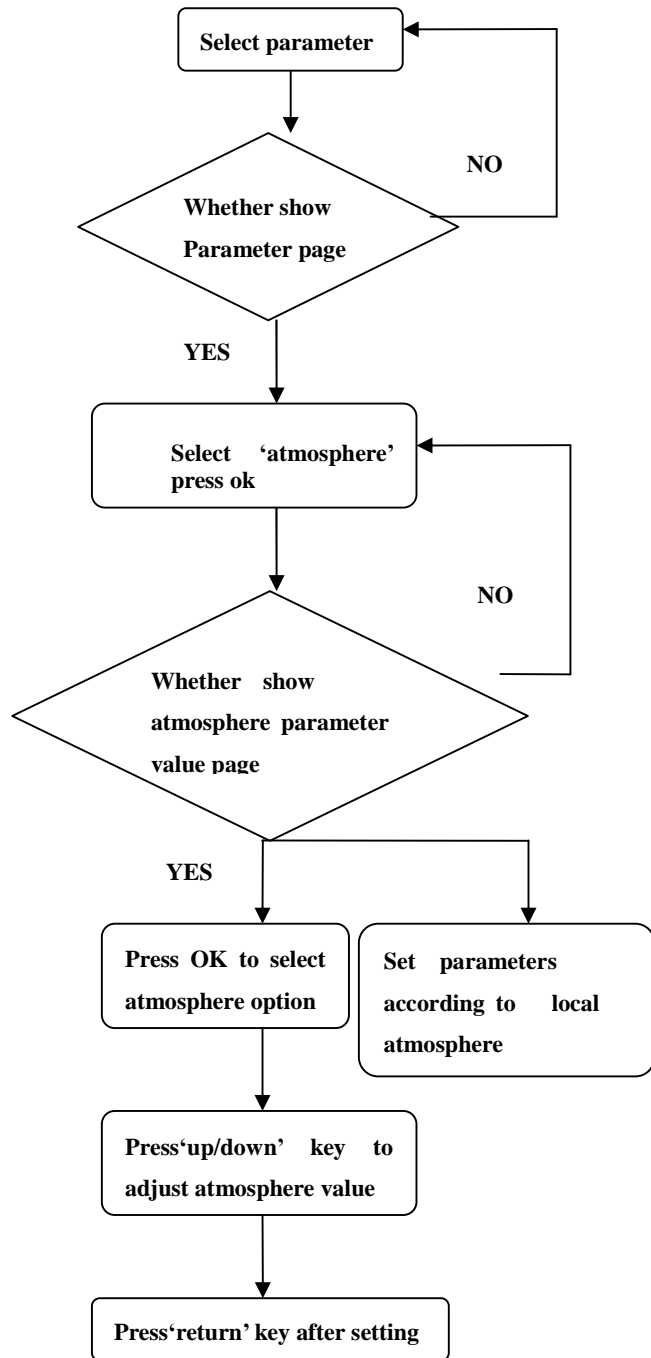
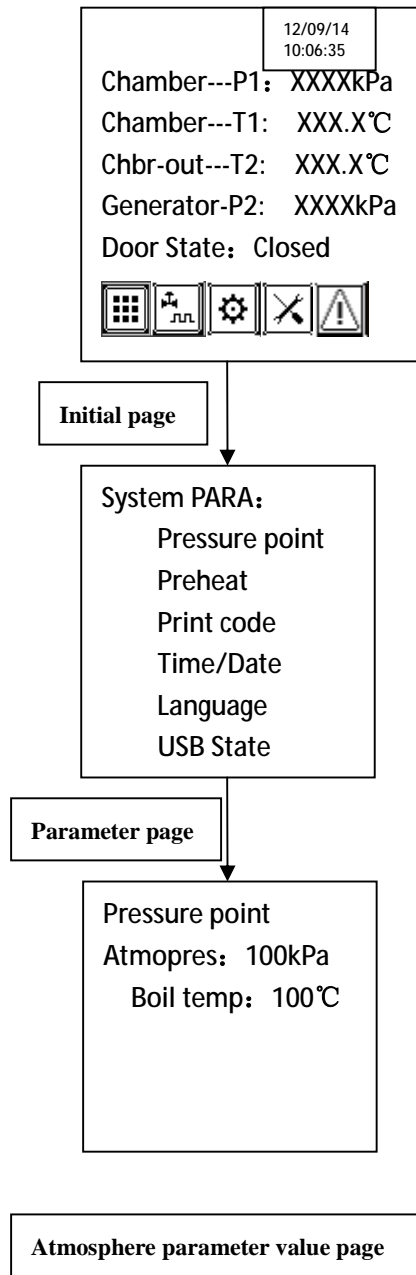

Caution:

The atmosphere value should be set according to local atmosphere. Since the system calculates boiling temperature value automatically according to local atmosphere, there is no need to adjust manually.

2.3.2 Preheating mode setting

Preheating mode setting process:

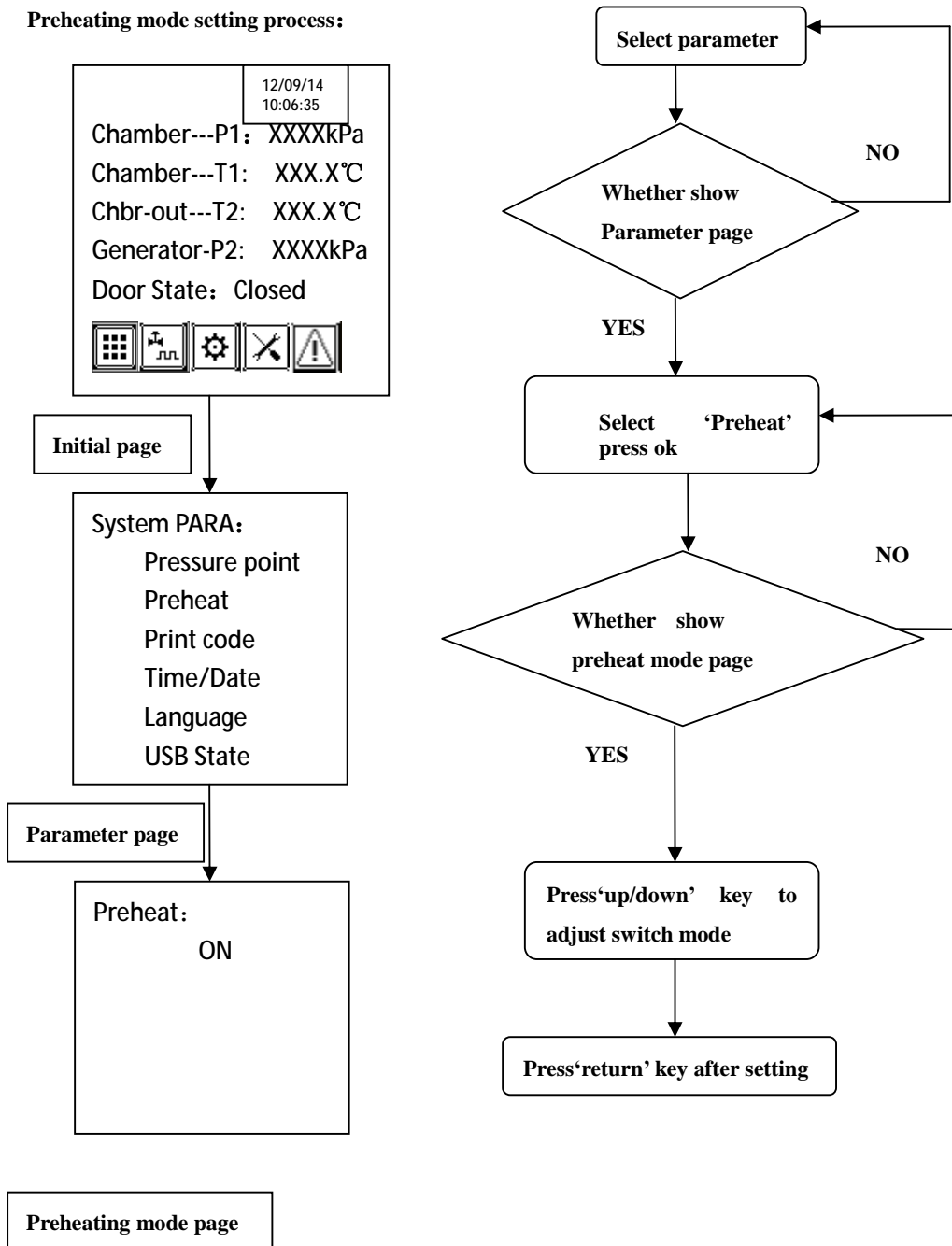

2.4 Equipment connector instruction

2.4.1 Water tank outlet a

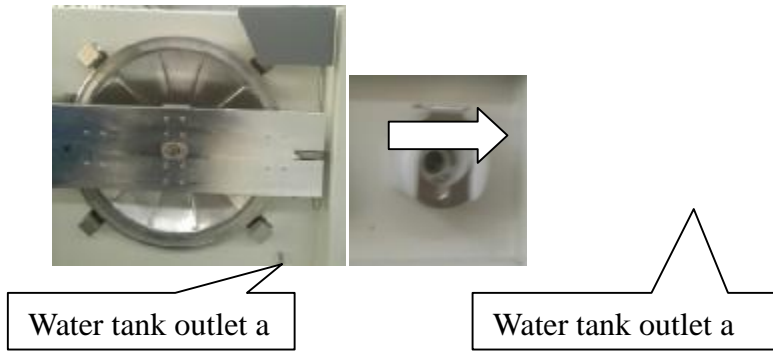

'Water tank outlet a' is used for draining. Please plug a specialized connector in the 'outlet a'. Push the little slice on the top of the connector to pull out the draining pipe.



2.4.2 Steam generator water outlet d

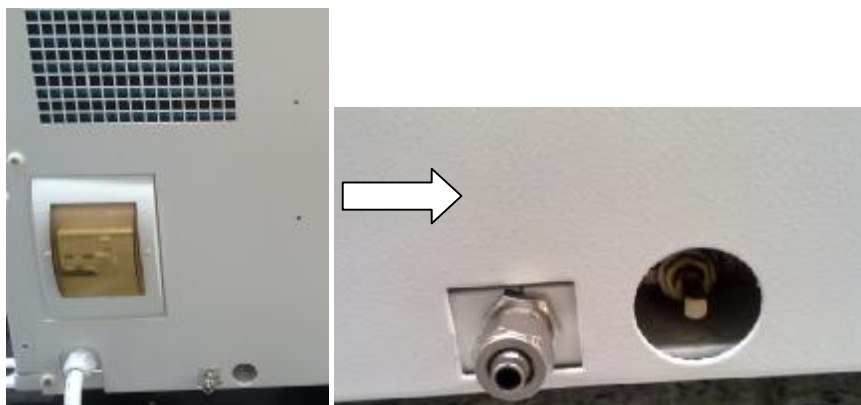

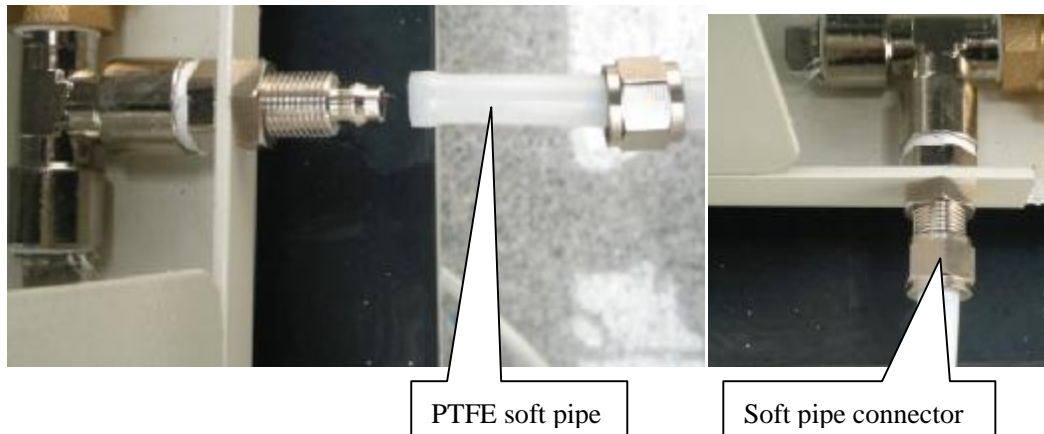

Before drainage, a PTFE soft pipe (attached accessories) should be connected to the outlet. Please use specialized rotate tool.

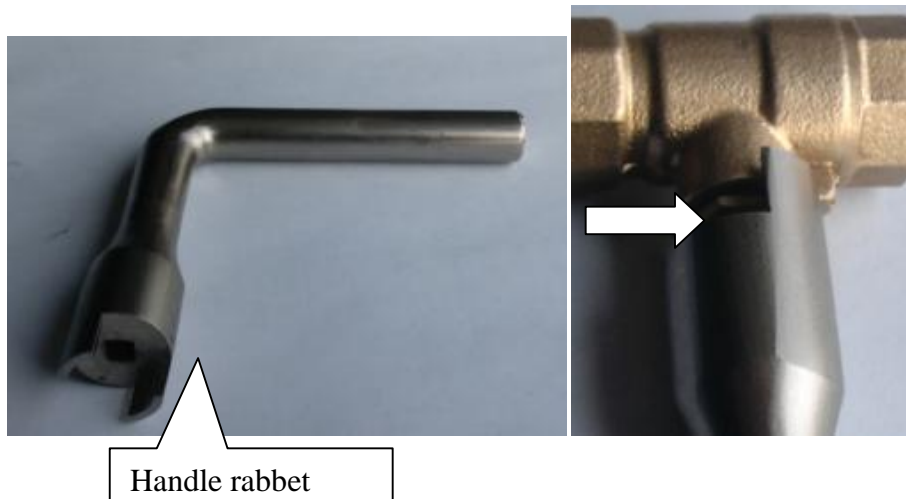

Plug ledge of the ball valve into the handle rabet and twist 90° to drain water. Twist the handle 90° reversely after drainage.

2.5 Water injection operation

- ◇Get the water and a small water container ready. The quality of water should meet relevant requirement.
- ◇Take off the water tank lid.
- ◇Inject pure water into the tank till the water level comes between high and low level (about 16L).

2.6 Operation of opening/closing door

The equipment adopts multi-point lamination and auto door motor device. When the door is being opened or closed the screen displays: opening or closing door.

Door operation process (open)

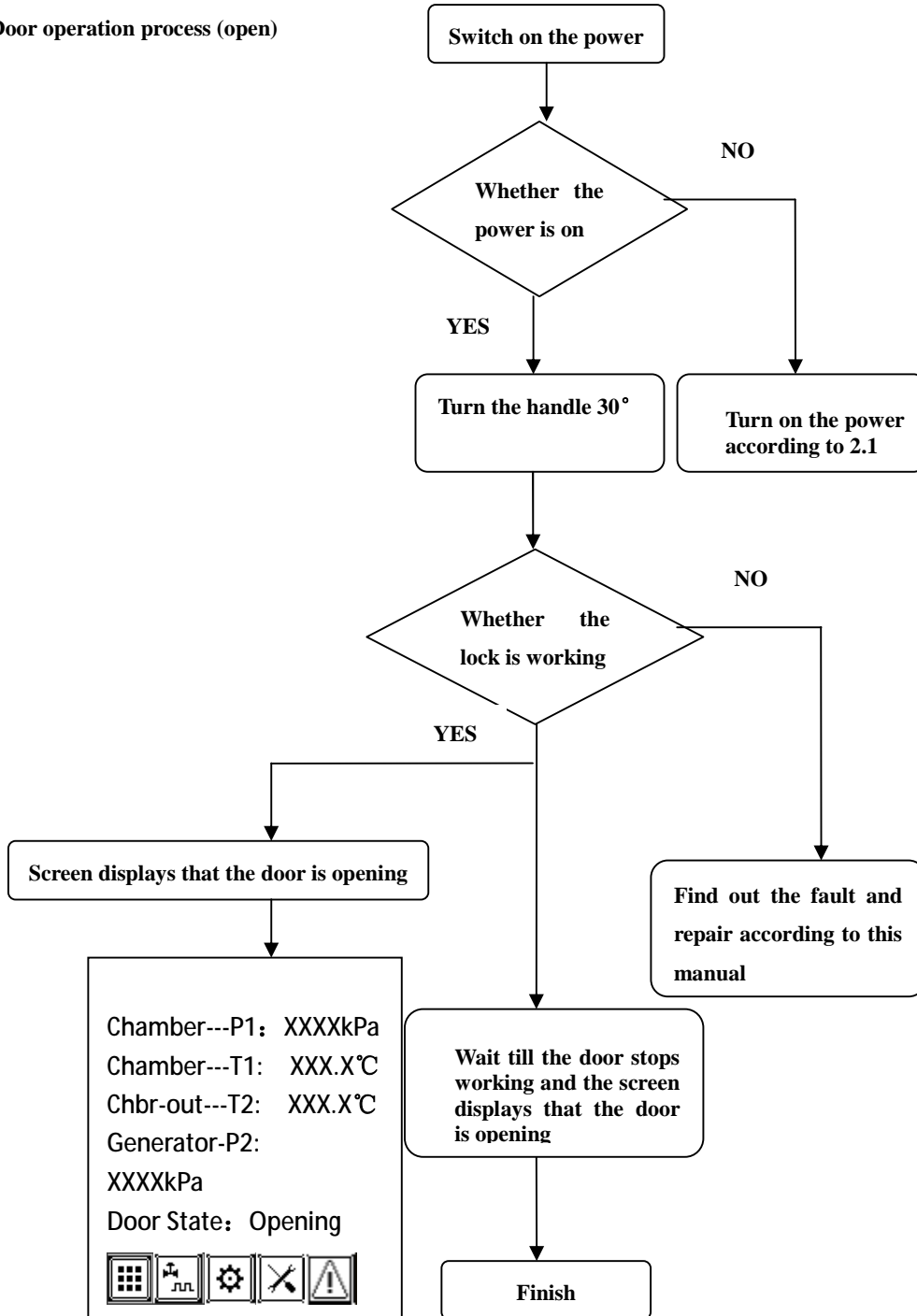

Operation of closing door

Push the door and turn the door handle to close door. The door will be automatically closed once the lock reaches the switch contactor.

Door operation process (close)

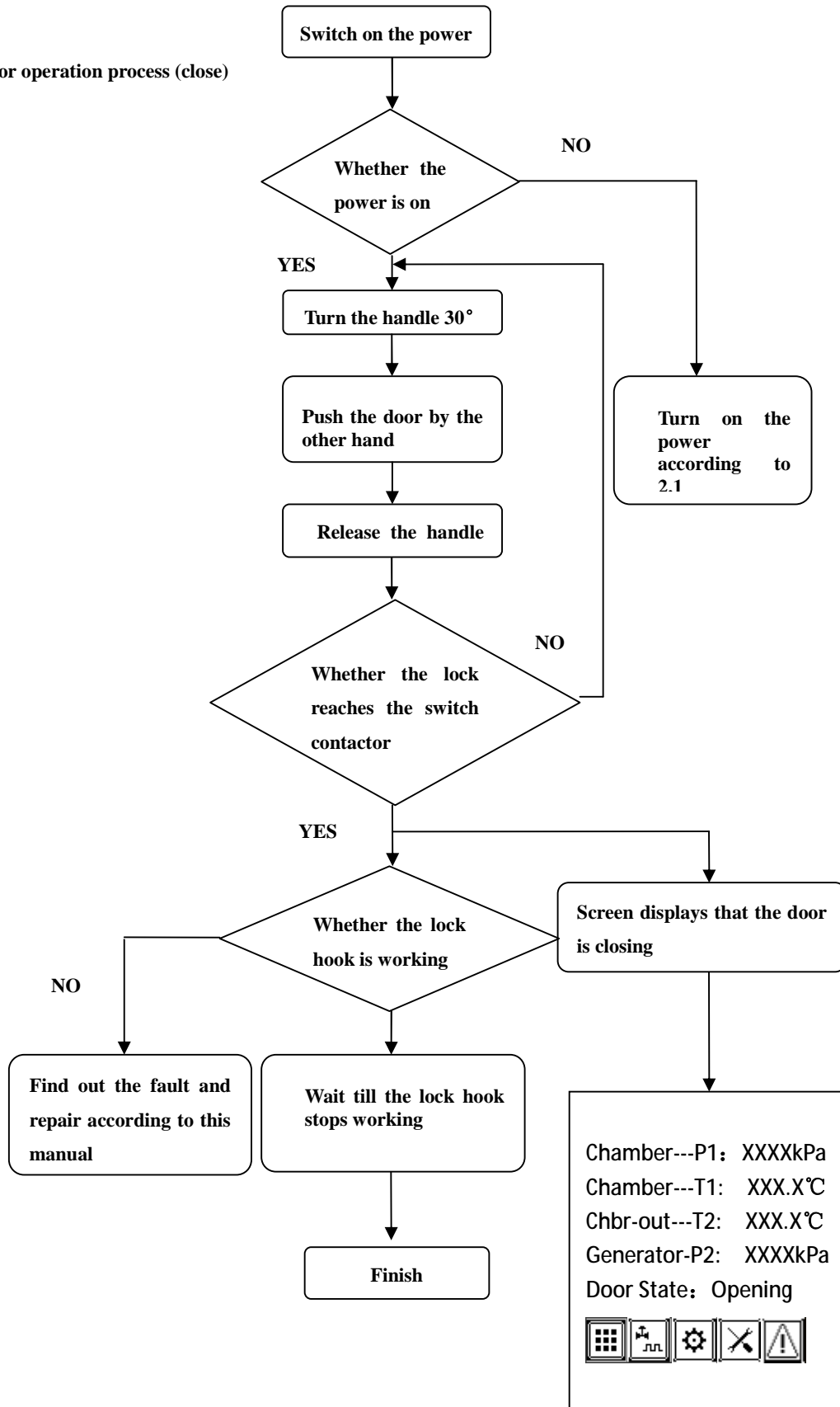

Door operation device instructions:

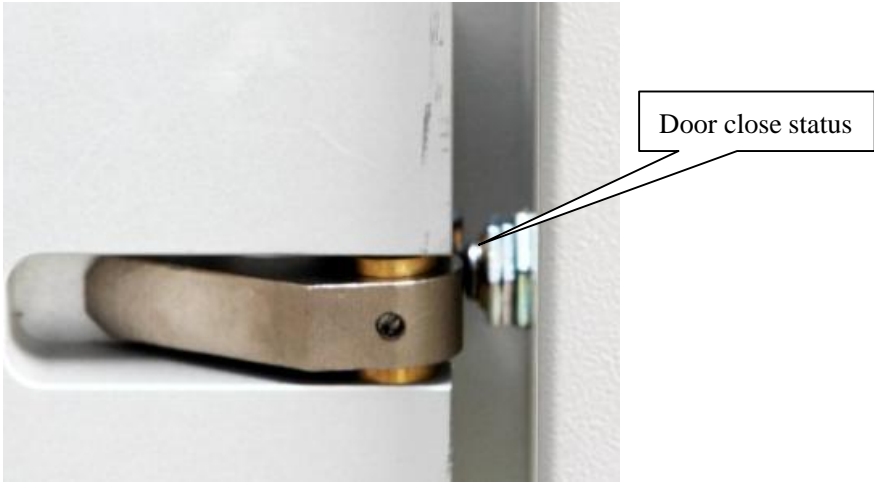
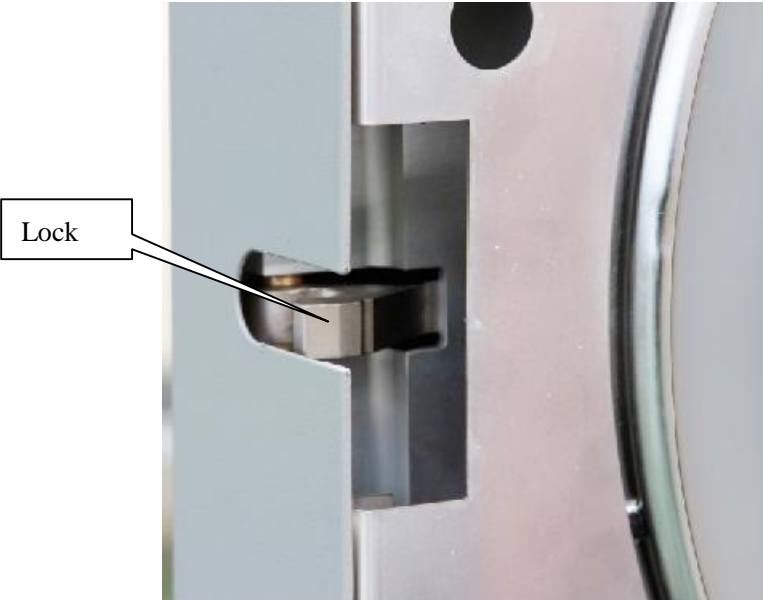
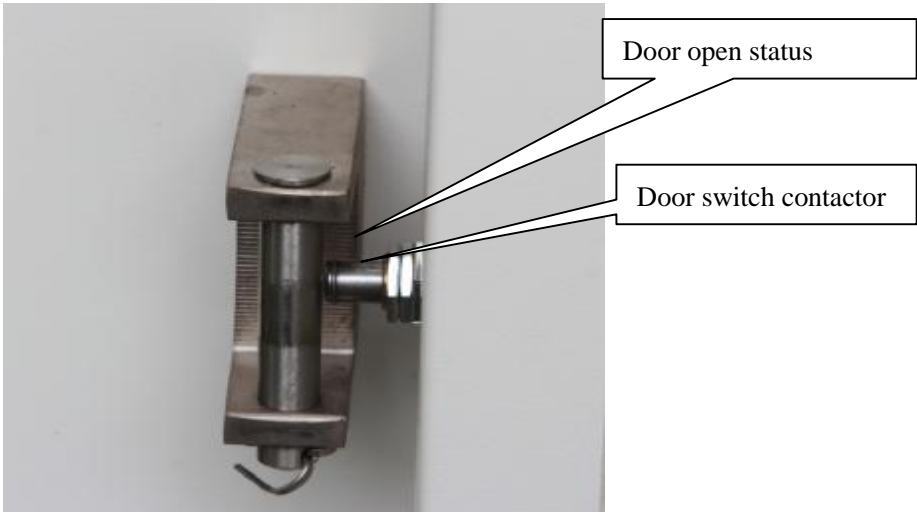

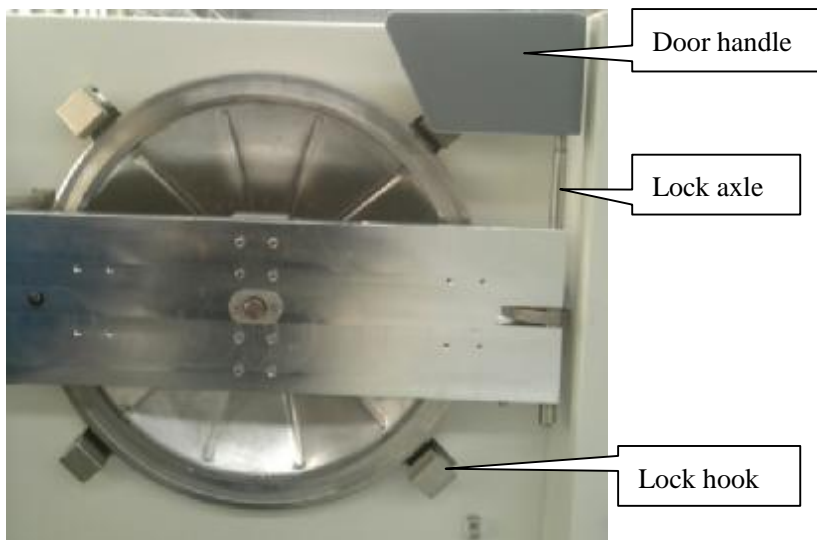

Instructions:

- a) **The lock axle is used for connecting the door handle and the lock. The lock axle will be turned by turning of the door handle.**
- b) **The door motor works to open or close door by driving the four lock hooks.**
- c) **Close the door and turn the handle manually to close the door by driving the lock presses the switch contactor.**
- d) **To open the door, please turn the handle to disconnect the switch contactor.**



Caution:

When use the 'open' key to open the door, the door will close automatically after 30 seconds if the handle is not turned. When close door, the equipment will take 10 seconds to vacuum the chamber.



Caution:

Please keep the door in open status after operation, especially after the last usage of the day.

2.7 Operation of sterilization program

◇Do the preparation work according to the relevant information in this manual. The equipment should be operated with no load for first usage.

◇Select a sterilizing program, for example instrument program, observe whether the program runs normally. Check whether there is any leakage in pipeline and water tank. Please repair it in time if any.



Caution:

After water injection if the system indicates that the water quality is poor, please change another tank of water in good quality.

2.8 Operation of vacuum test program

◇If there is any leakage after running a sterilizing program please repair it according to relevant information in this manual.

◇Select the vacuum test program to test the vacuum degree and tightness of the chamber. If there is any leakage or poor tightness please repair it according to relevant information in this manual.

2.9 End of installation and debugging

3 Display screen instructions

3.1 Initial page

Initial page 1

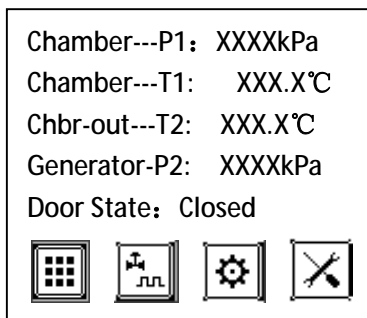

Program selection icon



Input/output signal view icon



System maintenance icon



System parameter icon



Warning icon

3.2 Program selection & start page

3.2.1 Program selection page

Select the program selection icon  on the initial page to enter into the program selection page.

Page 2: Program selection page

P1: XXXXkPa T1: XXX.X°C
P2: XXXXkPa T2: XXX.X °C
Cycles : XXXX
DviceID: XXXXXX

Sterriize Program
Test Program

After selecting the sterilization program Page 3 will appear.

Page 3: Sterilization program selection page

Program Select
Unwrapped
Wrapped
Rubber
N-clase
Quick

After selecting the testing program Page 4 will appear.

Page 4: Testing program selection page

Test Program
B&D Test
Helix
Lesk Test

3.2.2 Program start page

Press OK key after a program is selected on the program selection page (Page 3) to enter into the program start page (Page 5).

Page 5: Program start page

P1: XXXkPa T1: XXX.X°C
P2: XXXkPa T2: XXX.X°C
Pro.NO.: XX
Type : XX
PARA: XXX.X°C/XXXX S
Door State: Closed



 **Start icon**

 **Parameter review icon**

 **Parameter setting icon**

3.3 Setting pages

3.3.1 System parameter setting

Select system parameter setting icon  on the initial page to enter into Page 6.

Page 6: System parameter setting page

System PARA:
Pressure point
Preheat
Print code
Time/Date
Language
USB State

- **Pressure point:** adjust the atmosphere value according to local atmosphere. The boiling point will be automatically calculated according to the atmosphere value.
- **Preheat:** turn on the preheat mode, the steam generator and chamber inwall will be preheated automatically in the stand-by status.
- **Print mode:** select print or do not print.
- **Time/Date:** set present time and date.
- **Language:** select language.

- **USB state: view USB connection.**

3.3.2 Pressure point

Select 'Pressure point' and press OK to enter into pressure parameter setting Page 7.

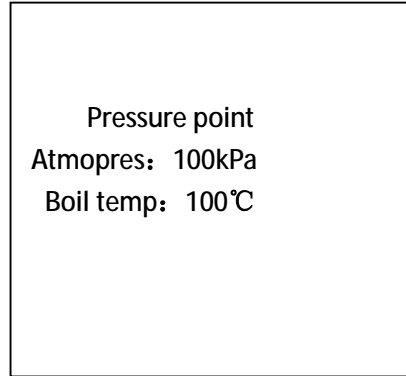

The boiling point will be automatically calculated according to the atmosphere value.

3.3.3 Preheat

Press OK key after selecting this item to enter into the preheating mode setting page 8.

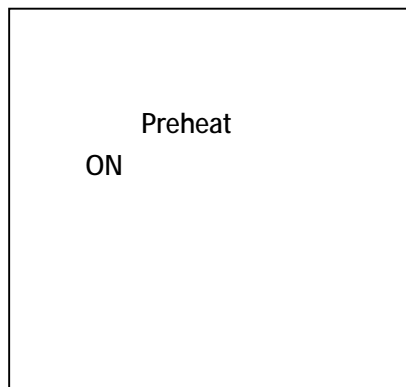

When the preheat mode is on, the steam generator will be injected water and preheated automatically. The default setting of this mode is off.

3.3.4 Print mode

Select print mode to enter into Page 9.

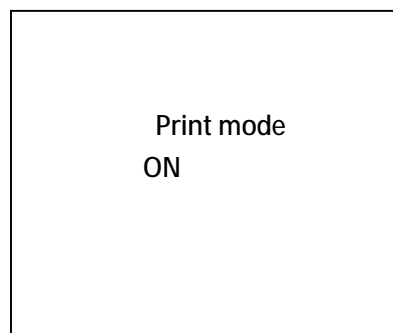

The printer works when the print mode is on. The default setting of this mode is on.

3.3.5 Time/Date

Select this item and press OK key to enter into the time setting page 10.

Page 10: Time setting page



3.3.6 Language

Page 11: select and print English or Chinese information.



3.3.7 USB connection status

Page 12: view USB connection status

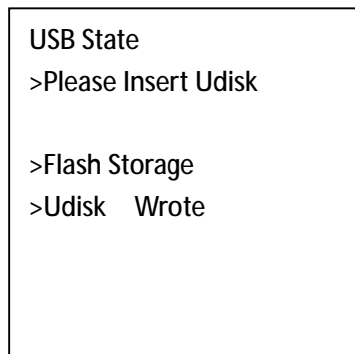

View and check the USB connection status whether data can be wrote in.

3.4 Maintenance

Select the system maintenance icon  on the initial page and press OK key to enter into the password page 13.

Page 13

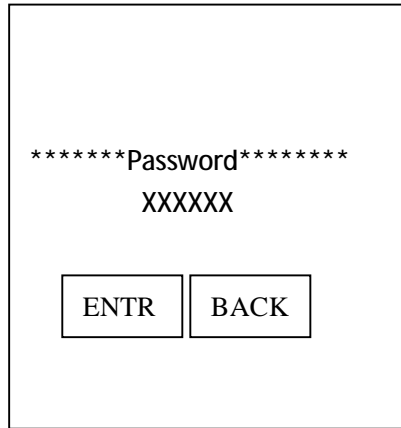

*****Password*****
XXXXXX

ENTR BACK

Type in the password to enter into Page 14. Only authorized operator or maintenance staff could set the parameters.

Page 14

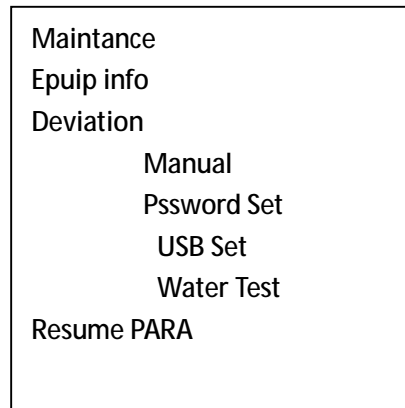

Maintance
Equip info
Deviation
 Manual
 Pssword Set
 USB Set
 Water Test
Resume PARA

3.4.1 Equipinfo

Select 'Equip info' in Page 14 to enter into equipment information Page 15.

Page 15



Setting method: press up/down key to select the numbers or letters that to be edited; press up/down key to edit the selected numbers or letters.

LCD: Brightness adjustment

3.4.2 Deviation

Select 'deviation' in Page 14 to enter into Page 16

Page 16

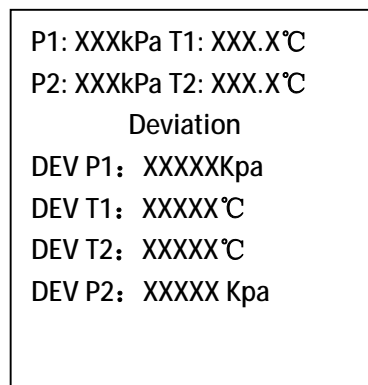

Setting method: press OK key to select item that to be edited;

press up/down key to edit the selected item.

P1: chamber pressure deviation

Setting range 【-10 10】 Kpa

T1: chamber temperature deviation

Setting range 【-5+5】 °C

P2: steam generator pressure deviation

Setting range 【-10 10】 Kpa

T2: Chamberinwall temperature deviation

Setting range 【-5+5】 °C

3.4.3Manual

Page 17: operate the output points manually

Manual			
F2	off	B1	off
F3	off	H1	off
F4	off	H2	off
F5	off	LK	off
F6	off		
P1:	XXXkPa	T1:	XXX.X°C
P2:	XXXkPa	T2:	XXX.X°C

3.4.4 Password set

Page 18: set new password

Passwrđ Set	
Password:	****
Newpassword:	****
Confirm:	****
ENTR	BACK

3.4.5 Water test

Page 19: view water test value and set up/lower limit of water test value.

Water Test	
Test value :	0000
Upper value:	****
Lower value:	****
ENTR	BACK

3.4.6 Resume PARA

All the parameters will back to default value by selecting default value and press OK key.

3.4.7 Program parameters setting

Select the program parameter setting icon  in program start page to enter into the password page. Type in the password to enter into the parameter setting

page. Select the program parameter view icon  in the program start page to enter into Page 20.

Page 20:

PARA: XX # XXXXXX Ster.time: 4 min Ster.tem: 134 °C Dry.time: 10 min Plus.time: 3 次 H.Pluse: 60kPa L.Pluse: -80kPa Purg.time: 240 s





3.5 Program pages

Select the program start icon  in the program start page to enter into the program process page.

3.5.1 Main process page

Once a program starts, the system will firstly enter into the preparation phase.

Page 21: Main process page

XXX #XXX P1: XXXkPa T1: XXX.X°C Preheat Running: 00:00 Door state: Closed     

Page 22: Final phase

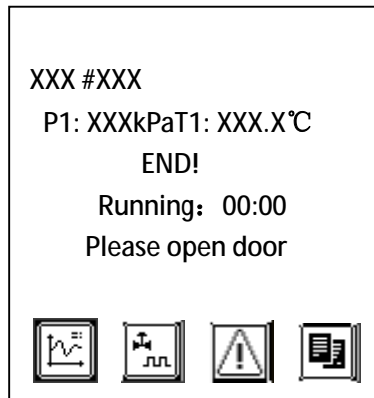

3.5.2 Parameter view

Select the data review icon  in process page to enter into the parameter view page.

Page 23:

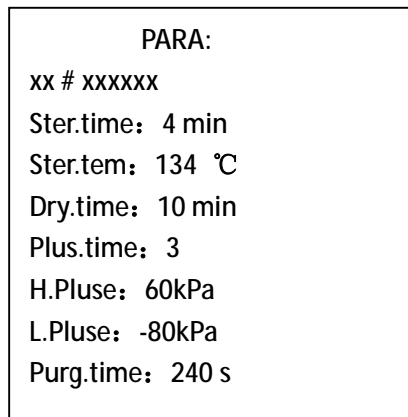

Press up/down key to change pages.

Page 24: view parameters

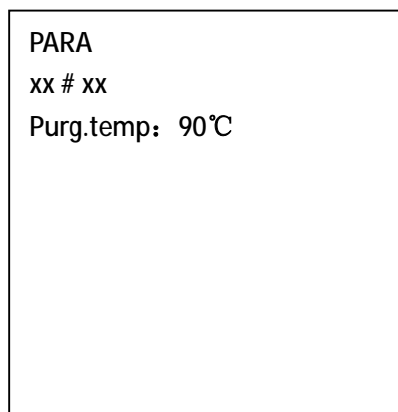

3.6 Output information

Select the output information icon  in main process page to enter into the

output information page 25.

Page 25:

P1: XXXkPa	T1: XXX.X°C
P2: XXXkPa	T2: XXX.X°C
F2 off	H1 off
F3 off	H2 off
F4 off	LK off
F5 off	I3 off
F6 off	I4 off
B1 off	I5 off
B2 off	I6 off

3.7 Process data

Select the process data icon  in main process page to enter into the process data page 26.

Page 26:

Phase Info	
Pur: 0:00	Ste: 0:00
Pv1: 0:00	Max: 0:00
Pp1: 0:00	Min: 0:00
Pv2: 0:00	
Pp2: 0:00	
Pv3: 0:00	
Pp3: 0:00	

PV1: The actual operation duration from upper limit to lower limit

Pp1: The actual operation duration from lower limit to upper limit

Ste: Operation time of sterilization

Max: Maximum temperature in sterilization phase

Min: Minimum temperature in sterilization phase

3.8 Alarm information

Select the alarm information icon  in main process page to enter into the alarm information page 27.

Page 27:

P1: XXXkPa	T1: XXX.X°C
P2: XXXkPa	T2: XXX.X°C
NO.: XX	Phase: XX
Text: XX	
XXXXXX	
Occur: XX-XX-XXXX:XX:XX	
ACK: XX-XX-XXXX:XX:XX	

Alarm information table

No.	Warning Code	Description
1	E00	Interrupted
2	E01	Door-ST Error
3	E02	Chamber-T1 high
4	E03	Ch-out-T2 high
5	E04	Temp. Low
6	E05	Vacuum failed
7	E06	Heat failed
8	E07	Water Overtime
9	E08	Motor Overload
10	E09	Motor Overtime
11	E10	Over Pressure
12	E11	Generat.P2 high
13	E12	ChamberT1 Error
14	E13	Ch-out-T2 Error
15	E14	Genera.P2 Error
16	E15	ChamberP1 Error
17	E16	Water Lack

No.	Warning Code	Description
18	E17	Door Unlock
19	E18	Water SW ERROR
20	E20	Communic. Error
21	E21	Interrupted
22	E50	Door-ST Error

3.9 Program stop

Select the Stop icon  in main process page to enter the stop confirmation page 28.

Page 28:

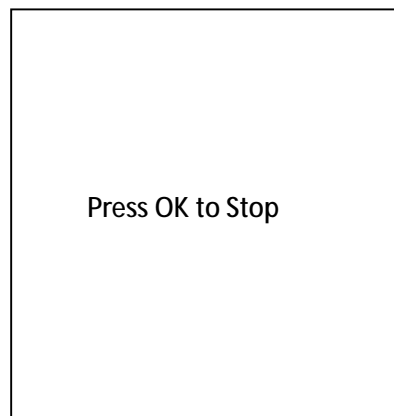

3.10 Other pages

3.10.1 Input/output view

Select information input/output icon  in the initial page to enter into input/output information view page29.

Page 29:

F2	off	LK	off
F3	off	I0	off
F4	off	I1	off
F5	off	I2	off
F6	off	I3	off
B1	off	I4	off
H1	off	I5	off
H2	off	I6	off

3.10.2 Vacuum test

The vacuum test page includes process page and result page. The process page is same as main process page 20.

Page 30: result page

<p>XXX #XXX P1: XXXkPaT1: XXX.X°C</p> <p>Result: pass Please open door !</p>
--

3.10.3 Alarm prompting

When system alarms you will see alarm prompting page 31.

Page 31:

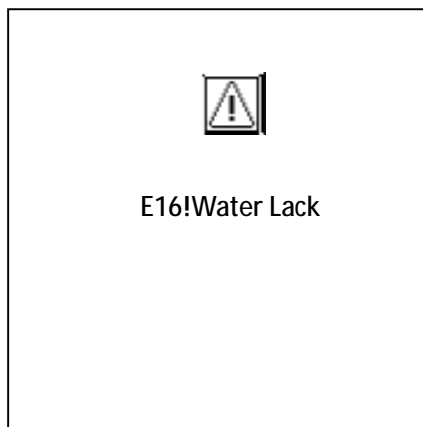

4 Operation instructions

4.1 Instructions on keys

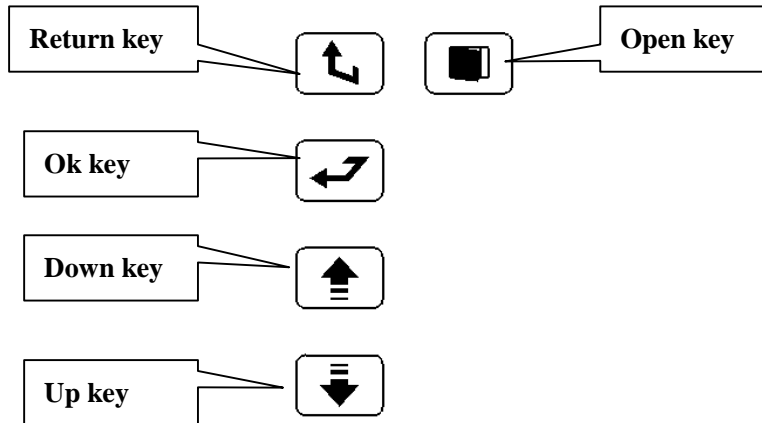

4.1.1 Return key

Press this key to return to the previous page.

4.1.2 Ok key

- Press this key to select the icon.
- When setting the parameters, this key can be used to move the cursor.

4.1.3 Up key

- Press this key to move the cursor upwards or leftwards.
- When setting the parameters, this key can be used to increase the value.
- Press this key to change page.

4.1.4 Down key

- Press this key to move the cursor downwards or rightwards.
- When setting the parameters, this key can be used to decrease the value.
- Press this key to change page.

4.1.5 Open key

When the motor is jammed, please press the Open key to open the door. In normal conditions, simply turn the door handle and the door will be opened automatically.

4.1.6 Cursor

When the cursor is moved to the icon or parameter selected, the color of such icon or parameter will change:

Example: The cursor is not moved to icon



The cursor is moved to the icon



4.2 Program parameters setting

Select the parameter setting icon  on the program start page 5 to set the program parameters.

- Select parameter setting icon to enter into the password page. Type in the password to enter into the parameter setting page.
- Select the name of the parameter that to be edited by pressing the Ok key to move the cursor on parameter setting page.
- Leave the cursor on the parameter that to be changed and edit the value by pressing the Up/Down key.
- Press the Return key to return after setting.

PARA:

xx # xxxxxx
 Ster.time: 4 min
 Ster.tem: 134 °C
 Dry.time: 10 min
 Plus.time: 3 次
 H.Pluse: 60kPa
 L.Pluse: -80kPa
 Purq.time: 240 s

No.	Program Type	Sterilization Temperature /°C	Sterilization Time/S	Drying Time/S	Times of Vacuum Pulsation
1	Unwrapped Program	134	240	360	3
2	Wrapped Program	134	360	600	3
3	Rubber	121	1200	600	3
4	N-class Program	134	360	600	0
6	Quick Program	134	240	300	2
7	B&D Test	134	210	120	3
8	Helix	134	210	120	3
9	Leak Test	300s for vacuum pumping, 300s for balancing and 600s for testing			

Ster.P: Operation time of sterilization phase, of which the range is [0 999] min

Ster.temp: Temperature to be maintained in sterilization phase, of which the range is [105 136]°C

Drytime: Operation time of drying phase, of which the range is [0 999] min

Plus.time: Times of pulsation vacuum, of which the range is [1 6]

H.Plus: Upper limit of pressure in pulsation phase, of which the range is [50 90]

L.Plus: Lower limit of pressure in pulsation phase, of which the range is [-90 -50]

Prug.time: Operation time of exchange phase.

Note: Among the above sterilization programs, only the parameters of Programs No.1-4 can be set, the rest of them cannot be set.

Instructions:

The system is equipped with a total of 8 default programs, among which the programs No. 1, 2, 3, 4 and 6 are sterilization programs, while the program 7, 8 and 9 are test programs.

- All the default values of technological parameters are under the standard loading conditions as specified in the product standard. If the load or loading mode has been changed by user, the relevant value might be used only after the relevant technological verification has been carried out. (Users should firstly make sure that the items to be sterilized can be operated in the technological process corresponding to the program selected).
- Programs 1, 2, 3 and 6 are pulsation/vacuum based sterilization program and their technological processes are same, with the only difference that the value of relevant parameters is adjusted on the basis of the characteristics of various loads.
 - Program 1 is mainly used to sterilize the exposed metal articles which are unwrapped and can resist high temperature. For example, the standard simulated load is solid metal screw.
 - Program 2 is mainly used to sterilize the wrapped articles which can resist high temperature. For example, the standard simulated load is metal screw wrapped with paper or plastics and fabric article wrapped with cloth.
 - Program 3 is mainly used to sterilize the rubber articles of which the heat resistance is relatively low.
 - Program 6 is only used to sterilize single exposed instruments in emergency circumstance. Such sterilized instruments must be used within 4 hours after sterilization and should be protected against secondary contamination caused by environmental factors during the transportation.
- Program 4 is the steam-discharging program to be used in emergency circumstance when the vacuum system of this equipment fails and the

pulsation/vacuum based sterilization program cannot be used. This program does not involve vacuum pumping and drying, so that the drying effect cannot be guaranteed. In addition, before using this program please make sure that the items that to be sterilized can be effectively sterilized under this technological condition. For example, this program may not be used to sterilize the tube/cavity instruments.

- Program 7 is used to, in conjunction with special materials, test the discharging effect of cold air and the penetration effect of steam for items such as standard BD kit and disposable BD kit. As for this program, the parameters should be set on the basis of the value required by manufacturer of most widely used BD testing paper (sterilization for 3.5mins at 134°C). If it is different from the material or testing paper adopted by hospital, the specific parameters should be changed by referring to the hospital requirements of the material or testing paper adopted by hospital.
- Program 8 is used to, in conjunction with special tube/cavity PCD, test the discharging effect of cold air and the penetration effect of steam for tube/cavity instruments of certain length. As for this program, the parameters should be set on the basis of the value required by manufacturer of most widely used PCD instruments (sterilization for 3.5mins at 134°C). If it is different from the parameters that the hospital requires please edit those parameters according to specific requirements of instruments.
- Program 9 is used to test the sealing performance of pipe or device connected to chamber in the negative pressure state. In the course of adjustment or routine inspection/testing of this equipment, especially after long-distance transportation. It is very likely that some pipes are loosened (or when the BD test is disqualified). In such case, you may select this program to carry out testing. It is mainly used to inspect the vacuum leakage of this sterilizer, so as to inspect the sealing performance of pipe. This testing should be carried out under the precondition that the sterilizing chamber is unloaded. After the operation enters into the testing phase, if the change in pressure during 600 seconds does not exceed 1.3KPa, the vacuum leakage testing should be deemed as qualified. If the testing fails, inspection and repair should be carried out. Please inspect the sealing of door and the connection between pipeline system and chamber, identify and eliminate the leakage point and carry out the testing again until the testing is qualified. **This program is only used for testing rather than verifying whether the sterilization is qualified and reliable.**

5 Operation steps of sterilization

5.1 Preparation

- 1) **Water adding:** switch the power supply and add appropriate amount of water into clean water tank. The beep of buzzer during the water adding means that the water level in the tank has met the lowest requirement. Please keep adding water till the amount reaches the high level.



- 2) **Energization:** connect the main power supply and control-purpose power supply and turn the power switch of sterilizer to '1' position to get ready for operation.
- 3) **Preparation:** mark the BD testing paper with the name or code of operator and date and place it into the sterilizer. Start the BD testing program and monitor whether there is any leakage or the equipment works normally. Set the parcel that to be sterilized in right order and make sure that it is not bound too tight. Paste the chemical indicator tape on it and put the chemical indicator card in the chamber.
- 4) **Item placement:** open the front door after the BD test is successfully done. Place the items that to be sterilized into the chamber, and make sure that there is clearance between every two items. There must be no items contacts with inner wall or door plate of the equipment.



Warning: The maximum load of the equipment is 14Kg!

- 5) **Close the door:** close the door and turn the door handle, so as to make the latch hook on door handle connecting rod pressed against the latch. The motor will automatically run so as to close the sealing face (The message 'door is closing' will be displayed on screen.). If press the door manually when the motor is running, the closing of door will become smoother. The message 'door closed' will be displayed on screen after the door is properly closed.



5.2 Operation of sterilization

- 1) **Selection of program:** Select the sterilization program or testing program on the basis of the items that to be sterilized. Inspect whether the sterilization parameters are appropriate.

Program Select
Unwrapped
Wrapped
Rubber
N-clase
Quick

- 2) **Starting of program: If any parameter is found inappropriate after the program parameters are set, please reset such parameter according to relevant section of this manual. Select the start icon and press Ok key to start the program.**
- 3) **Sterilization: In the course of sterilization, the operator should not get far away from the equipment, but closely observe the operation of equipment. If any abnormal situation is found please handle it in time to prevent the occurrence of any accident.**
- 4) **End of program: The final page appears and the buzzer sounds.**
- 5) **Opening of door: After the reminding process is completed, turn the door handle by about 45° and the motor starts working (the angle of door handle must remain unchanged). Once the motor stops, the screen will give the message ‘door opened’. Pull the door handle to open the door.**
- 6) **Taking out items: Use the special tool to take out the tray. Take care not to get scalded. Please monitor the sterilization effect and properly record it for traceability purpose. Take out the sterilized article from the sterilizer and put in an appropriate place to prevent the secondary contamination.**

5.3 Cleaning and maintenance

- a) **Open the door. Turn the power switch to ‘○’ side and cut off the control-purpose power supply and main power supply.**
- b) **Take out the tray. Use special tool to take out the tray. Take care not to get scalded.**
- c) **Water discharging. Discharge the residual water in steam generator (or fully discharge the accumulated water once a week).**
- d) **Cleaning. Clear away the residual dirt in the chamber and clean up the strainer to prevent the strainer from being blocked up. (Please refer to the service manual for cleaning).**
- e) **Requirements. Please maintain the equipment regularly according to the following requirements.**
- f) **Notice:**
 - i. **No items that have been sterilized can be placed together with those that have not been sterilized.**

ii. The items that have been successfully sterilized should be marked with sterilization date and qualified sign.

No.	Component	Maintenance Interval	Maintenance Requirements	Remarks
1	Chamber	Once a day	Clean and free of water and dirt	
2	Chamber strainer	Once a day	Clean and free of water and dirt	
3	Tray	Once a day	Clean and free of dirt	
4	Water tank	Once every two weeks	The wall of water tank should be free of dirt	
5	Water replacement for steam generator	Once a week	Attention should be paid to steam generator pressure	
6	Rubber door strip	Once a week	The rubber door strip should be free of dirt	
7	Cleaning of steam generator	Once every two weeks	Attention should be paid to steam generator pressure	
8	Water tank filter	Once every two weeks		
9	Motor gear	Once a month	Molybdenum disulfide should be applied to lubricate the gear.	
10	Door handle	Once a month	The door handle is firm and can be turned smoothly	

Note: The above maintenance interval should be adjusted flexibly in light of the actual use of this equipment to ensure that the performance of this equipment will be brought into full play to meet your needs better.

Note: Only pure water can be used for the equipment. The quality of water must meet the following requirements:

- a) **Electrical conductivity: $\leq 15\mu\text{S/cm}$**
- b) **Content of bleaching agent: $\leq 2\text{mg/l}$**
- c) **PH value: 5-7**
- d) **Hardness: $\leq 0.02\text{mmol/l}$**

Appendix 1 Operation specification

1. Preparation before Operation:

- ü Add softened water or pure water into clean water tank and circulating water tank in accordance with the requirements, and connect the power supply for this equipment.**
- ü Connect the control-purpose power supply, turn the power switch of sterilizer to “1” side, and make proper preparation for operation of the program.**
- ü Mark the B-D testing paper with the name or code of operator and date, place it into the sterilizer, start the B-D testing program, and monitor whether this equipment leaks and whether this equipment works normally.**
- ü Set in order the parcel to be sterilized, make sure that it is not bound too tightly, paste the chemical indicator tape on it, and place the chemical indicator card in the chamber.**

2. Operation of Sterilization:

- ü After the B-D testing is successfully carried out, open the front door, place the article to be sterilized into the sterilizing chamber, and make sure that there is clearance between every two parcels and no parcel contacts with inner wall or door plate.**
- ü Close the front door, select the appropriate sterilization program in light of the article to be sterilized, inspect whether the sterilization parameters are correct, and start the program.**
- ü In the course of sterilization, the operator may not get far away from this equipment, but shall closely observe the operation of equipment. If any abnormal situation is found, please handle it in time, so as to prevent the occurrence of any accident.**
- ü Monitor the sterilization effect and properly make and retain the record, so as to ensure the traceability.**
- ü After the sterilization is completed and the pressure in sterilizing chamber returns to zero, open the rear door and take out the article.**
- ü After taking out the sterilized article from the sterilizer, put it in an appropriate place, so as to prevent the secondary contamination.**

3. Works after Operation:

- ü Open the door, turn the power switch to “○” side, and cut off the control-purpose power supply and main power supply.**
- ü Discharge the residual water in water tank, or discharge the water in accordance with the required interval.**
- ü Discharge the residual water in steam generator (or fully discharge the water accumulated in evaporator in accordance with the required interval).**
- ü After the works are completed every day, please keep the inside and outside of**

sterilizer clean, clear away all dirt from the chamber, carry out simple maintenance once a week, and carried out thorough maintenance once a month.

4. Notices:

- ü No article which has been sterilized may be placed together with unsterilized articles.**
- ü The articles which have been successfully sterilized shall be marked with sterilization date and qualified sign.**

Name of User:

Date: